

IONOSPHERIC NETWORK ADVISORY GROUP (INAG)\*  
IONOSPHERIC STATION INFORMATION BULLETIN No. 38\*\*

	<u>Page</u>
1. Introduction	2
2. INAG Meetings	2
3. World Data Centres for the Ionosphere	2
4. Meetings - Reports and Announcements	3
5. Station Notes	4
6. New Ionosondes	5
7. Low Latitude Problems	7
8. Deriving the M(3000) Factor From the X-Trace	8
9. An Ionosonde Test Unit	9
10. A Day-Time Crossing of the Auroral Oval at Halley Bay, Antarctica	10
11. KEL Aerospace Pty Ltd Products	13
12. International Geophysical Calendar for 1983	15

\* Under the auspices of Commission G, Working Group of the International Union of Radio Science (URSI).

\*\* Prepared by A S Rodger, British Antarctic Survey, Madingley Road, Cambridge, CB3 0ET, UK. Issued on behalf of INAG by World Data Centre A for Solar Terrestrial Physics, National Oceanic and Atmospheric Administration, Boulder, Colorado 80303, USA. This Bulletin is distributed to stations by the same channels (but in the reverse direction) as their data ultimately flow to WDC-A. Others wishing to be on the distribution list should notify WDC-A.

## 1. INTRODUCTION

by W R Piggott, Chairman

In several recent issues of the INAG Bulletin, I have drawn attention to the value of studying ionograms locally, as well as providing data for the network. The most serious gap in our knowledge at present appears to be the behaviour of the ionosphere at low latitudes, say within  $\pm 35^\circ$  magnetic dip latitude and the study of the forces which are dominant in that zone. Several groups have asked for guidance on possible lines of research and I have written a short note on these for this Bulletin. It has not been possible for me to investigate these possibilities properly, but there is time for those interested to at least find out what really happens before the next Equatorial Aeronomy Symposium at Hong Kong in March 1984. I would like to hear from anyone interested during 1983 so that I can arrange a workshop or discussion in Hong Kong. In my view, we really need a Low Latitude Supplement to the Handbook, similar, but probably smaller than, the High Latitude Supplement (there are fewer stations involved). This would involve at least a few stations selecting typical ionograms and ionogram sequences. Would anyone be willing to make a single station selection for discussion in INAG? While typical low latitude ionograms were published in the IGY Atlas and in the IGY Guide, their scientific significance was not understood so that the most interesting sequences are not easily available. Meanwhile, the High Latitude Supplement contains much of direct interest to low latitude operators and should be obtained by all interested groups.

Brief data on two commercial ionosondes are given in this Bulletin. If you use an ionosonde which has not been described in past issues of INAG Bulletin, or in the Atlases of Ionograms, it would be helpful to the World Data Centres and to future users of your data to have a brief description with an ionogram with height and frequency scales identified in the INAG Bulletin. For stations which have recently changed their ionosonde we need both new and old samples. Many ionograms archived by the World Data Centres are no longer easily used as the data on the ionosonde was never provided or has been lost. I would again request manufacturers of ionosondes to inform INAG of their sales so that the new users become aware of the international publications available.

Please note the provisional dates for the next three major INAG Meetings and try to attend at least one of these or send your opinions to me or to your national representatives. I am trying to give you plenty of notice so that it is possible to obtain funds and permission in time - in the past some people have had insufficient time to do this.

I am pleased to inform you that several new stations have been installed recently. Fuller details will be given when the stations are known to be producing data. If you have just started a station, please inform me, so that this can be announced at the next INAG meeting and in the Bulletin.

## 2. INAG MEETINGS

### INAG Meeting, Hamburg, August 1983

Professor Fukushima, Secretary General of IAGA has kindly agreed for there to be an INAG meetin during

the IUGG/IAGA General Assembly in Hamburg, West Germany on the evening of Tuesday 23 August 1983. A provisional Agenda for the meeting is given below. If it will not be possible for you to attend this meeting, please write to your Chairman or Secretary with any comments you would like to make, or inform your national IAGA representative. It is important to have ideas and suggestions for improvements on INAG matters from as wide a cross-section of the Bulletin readership as possible. INAG meetings provide an excellent opportunity to discuss problems.

### A G E N D A

1. Chairman's Introduction
2. Status of Network
3. Status of New Ionosondes
4. Future of INAG
5. INAG Bulletin
6. High and Low Latitude Problems
7. Handbooks and Training Requirements
8. Scaling Rules

If you have any ionogram sequences you would like to discuss with INAG members, please bring them with you to the meeting or send them to your Chairman, prior to the meeting, so he can have time to study them in detail. There will be limited opportunities to have private discussions with the Chairman in the second week of the IAGA meeting.

A considerable number of new stations have been set up in the last few years and many existing stations have installed new ionosondes recently. The network is clearly active and healthy. However, despite the increase in numbers of INAG members, most INAG work is still being done by the Chairman and Secretary, and the smooth transfers of this work to new people, planned at Washington, is not proceeding rapidly. This meeting is probably the last opportunity to review the situation before the Florence meeting of URSI in 1984.

### INAG Meeting, Florence, Italy, 1984

The final dates for the URSI General Assembly at Florence are not yet available, but it will be held within the period 24 August 1984 - 4 September 1984. Early notice of this meeting is given as it is important that as many as possible INAG associates and members attend. As you will remember, Dr Piggott is due to retire as Chairman of INAG at this meeting and arrangements must be agreed for the continuance of INAG.

## 3. WORLD DATA CENTRES FOR THE IONOSPHERE

Each of the World Data Centres for the ionosphere, A in USA, B2 in USSR, C1 in United Kingdom and C2 in Japan, have published a new catalogue during 1982. The catalogues from centres B2, C1 and C2 contain ionospheric data under a number of different classifications, listed below:

- B1 Ionospheric Vertical Soundings
- B2 Top-Side Vertical Soundings
- B4 Oblique Incidence Soundings
- B7 Absorption - Method A1 (Pulse Echo)
- B8 Absorption - Method A1 (Riometer)
- B9 Absorption - Method A3 (CW Field Strength)
- B10 Ionospheric Drifts

- B12 Ionospheric Back-Scatter
- B13 Whistlers and VLF Emissions
- B14 Atmospheric Radio Noises
- C6 Sudden Ionospheric Disturbances (not in CI cat.)

The catalogue produced by WDC-A contains only information on vertical soundings (classification B1). This catalogue has been published in the UAG series No 85 and is edited by R O Conkright and H I Brophy.

The WDC-A catalogue contains lists of ionospheric data held by station, year and month and gives an indication of the completeness of the data for each month for all data which they hold. The B2, C1 and C2 catalogues only include data from 1957 to the present day. However, WDC-C1 has published a further catalogue of Pre-International Geophysical Year vertical incidence ionospheric data held at the centre.

The addresses of the World Data Centres are given below:

World Data Center A for Solar Terrestrial Physics  
N. O A A  
E/GC2  
325 Broadway  
Boulder  
Colorado 80303  
U S A

World Data Centre B2  
Soviet Geophysical Committee  
Molodezhnaya 3  
117296 Moscow GSP-1  
U S S R

World Data Centre C1 for Solar Terrestrial Physics  
Science and Engineering Research Council  
Rutherford Appleton Laboratory  
Chilton  
Didcot  
Oxfordshire  
OX11 0QX  
United Kingdom

World Data Centre C2 for Ionosphere  
Radio Research Laboratories  
2-1 Nukui-Kitamachi 4-chome  
Koganei-Shi  
184 Tokyo  
Japan

#### 4. MEETINGS - REPORTS AND ANNOUNCEMENTS

##### Report on URSI Fairbanks Symposium

by Professor Robert Hunsucker

During the week of August 9-13, 1982, a symposium "Radio Probing of the High-Latitude Ionosphere and Atmosphere: New Techniques and New Results" was held at the Geophysical Institute of the University of Alaska near Fairbanks (UAF) Alaska. Principal sponsors of the symposium were the international commissions G & H of URSI. Additional sponsors were the US Air Force Geophysics Research Laboratory, U S National Committee of URSI, Alascom. Inc and the University of Alaska.

Chairman of the Steering Committee and Convenor of the symposium was Professor Robert Hunsucker, ably assisted by Patricia Brooks and seven UAF faculty members. The technical Program Committee Chairman was Dr Ray Greenwald of the Applied Physics Laboratory of Johns Hopkins University, assisted by approximately eight international scientists active in Radio Studies of the High Latitude Atmosphere. All committee members were listed in the symposium brochure and other publicity for the meeting.

The symposium attendance was limited to approximately one hundred participants, in order to concentrate on the special topic of the meeting. By so limiting the attendance we were also able to have all the meetings in one room and avoid parallel sessions. Special interest groups, such as IDIG, INAG (INAG 37, p 3) and an informal working group on High-Power Ionospheric Modification held very useful meetings.

There were ninety-five registered attendees, plus several local graduate students. Sixty-nine papers were presented, including fifteen invited review papers at seven sessions from Monday to Thursday.

The sessions' titles were:

- i) Modification Experiments
- ii) Methods of High Latitude Radiowave Research
- iii) Solar Cycle Variations of the High Latitude Ionosphere
- iv) Radiowave Problems of Boundaries in the Magnetosphere - Ionosphere system
- v) Radiowave Studies of the Disturbed Polar Ionosphere
- vi) Neutral Atmosphere
- vii) Irregularities Large and Small

Friday was devoted to "Future Directions" and was chaired by Dr Ray Greenwald. This was one of the most rewarding and exciting of all the sessions, with twenty-three scientists describing briefly (in most cases!) their future plans.

All comments heard so far, indicate that it was a very successful meeting - even including rather nice weather and no mosquitos! Several participants have commented that "it was an outstanding meeting that combined the right people, the right topics, held at the right time and place!" Radio Science has agreed to publish a special issue covering most of the papers presented at this symposium. This issue is currently being assembled by Drs Millman, Greenwald and Hunsucker.

##### International Symposium on Equatorial Aeronomy, Hong Kong, 22-29 March 1984

The Seventh International Symposium on Equatorial Aeronomy (ISEA), to be sponsored by URSI (International Union of Radio Science), IAGA (International Association of Geomagnetism and Aeronomy), IUGG (International Union of Geodesy and Geophysics), COSPAR (Committee on Space Research), as well as several national organisations, will be held at the University of Hong Kong, March 22-29 1984.

It is anticipated that a broad variety of subjects bearing directly and indirectly on equatorial aeronomy will be discussed. Subjects include:

- Plasma irregularities and instability mechanisms
- D-, E- and F-region dynamics
- Coupling processes
- Geomagnetism
- Equatorial electrojet
- Solar planetary relationships
- Tropical atmospheric dynamics
- Equatorial atmospheric waves
- Atmospheric turbulence, gravity waves, and related phenomena
- Techniques (radio propagation, MST radar, lidar, airglow, satellite, etc.)

The final deadline for abstracts will be in November 1983. The registration fee will be U.S. \$50. A more detailed symposium circular will be available around February 1983.

It is hoped to be able to provide financial support for the travel of key scientists (preferably from developing countries), as has been done for the previous ISEA symposia.

For further information, contact:

G O Walker  
Physics Department  
University of Hong Kong  
Pokfulam Road  
Hong Kong

or

S Matsushita  
High Altitude Observatory  
National Center for Atmospheric Research  
Boulder  
Colorado 80307  
U S A

#### Chairman's Note

This is an excellent opportunity to renew interest in the work of the stations at magnetically low latitudes and to submit new work using ionosonde data. I hope to attend myself to help with this and a session is planned on the operation and use of the IPS-42 at low latitudes with technical support from the KEL company. May I encourage all low latitude groups to look at their data critically - I am now sure that there is much new science available.

#### 5. STATION NOTES

The publication of the provisional master list of ionospheric observatories in INAG 37 has stimulated considerable feedback. I am particularly grateful to Professor Gledhill, Drs Bowman, Brown, Dundas, Wilkinson, Mrs Morris, Miss Mitchell and Mrs Dickson for their contributions. Some corrections and amendments are given below, together with other station notes. Can I encourage other people who have noted errors and omissions or can provide additional information to write to Alan Rodger (address on page 1 of

this Bulletin) so that a revised master list can be produced in due course.

#### Port Stanley

The observatory at Port Stanley was made operational again on 22 October 1982. Medians for October, based on 9 values, have been produced and circulated.

#### Bribie Island

The geographic coordinates of the station are 27.05°S, 153.16°E. There are two ionosondes at this site, but they are only run for special campaigns.

#### Christchurch (Godley Head)

From 1 January 1983, an IPS-42 ionosonde will be operating at Eyrewell 43° 25.2'S; 172° 20.3'E. The ionograms from this site will be scaled to produce the published data.

#### Campbell Island

From 1 October 1982, an IPS-42 has been the observatory instrument.

#### Auckland

This station is still operational, but the data are no longer published.

#### Scott Base

The operational ionosonde will be an IPS-42 from early in 1983.

#### Re-Siting of Slough Observatory

Following the merger of the Appleton Laboratory with the Rutherford Laboratory, it became necessary to re-site the Slough Ionospheric Observatory. Fortunately, a site just over half a kilometre from the original site became available, thus allowing continuity of observations which now span more than half a century. The observatory has been re-equipped with a Digisonde 256, modified in some respects to permit output on microfilm, as the main instrument and an IPS-42 as the back-up ionosonde. The Digisonde became the Observatory instrument on 3 August 1982.

The new address is:

The Ionospheric Observatory  
c/o M.O.D. P.E.  
Admiralty Compass Observatory  
Ditton Park  
Slough  
SL3 7JE

The telephone and telex numbers remain unchanged and are:

Slough 44234 and 848369

respectively.

Taiwan  
Korean  
Indonesians

National Institute of Telecommunications Research,  
South Africa

The following note has been received from B Dundas.

The National Institute for Telecommunications Research is in the process of updating and modernising its vertical incidence sounding programme. Setbacks have been experienced since mid 1979 due to lack of staff. However, these difficulties have partially been overcome, and the following is a summary of the present position and future plans.

Marion Island closed down on May 15, 1980 due to lack of staff. Hermanus closed down due to technical difficulties, but it is intended to re-open in early October 1982.

Johannesburg is now operating using an IPS-42 ionosonde with good results and Hermanus is being equipped with a similar ionosonde. A new tower and antenna system has been constructed at both sites.

All parameters are being scaled and published with the exception of spread data, which are available on request. Spread data are scaled using the Australian system, i.e. 1, 2, 3, P or K for frequency spread and range spreading measured in 25 km increments also using P and K to denote the type of spread. All data are fed into a computer which not only gives medians at the end of the month, but checks the data for errors before printing. The data are now published in typed form, which is a vast improvement on the previously hand-written presentation.

Discussions are now taking place on obtaining a Barry chirp-sounder for Johannesburg and using it in conjunction with Rhodes University to study oblique incidence paths of less than 1000 km. Numerous other experiments may also be started, which to my knowledge, are not being pursued anywhere in Africa.

Marion Island film is being re-scaled, but the quality of the film is poor. Data will not be published, but are available on request. Similarly, the Tsumeb South West Africa film is being held in Johannesburg and is also available on request.

Present ionospheric research being carried out at this institute concerns computer modelling of ionospheric disturbances and their effect on propagation. Comparisons of the computed results and vertical incidence recordings show reasonable correlation. Rhodes University has a Barry chirp-sounder which they use to obtain oblique ionograms on the Grahamstown/SANAE path. This is too long and passes through the auroral belt so is not of much use in studying propagation for shorter paths in southern Africa.

## 6. NEW IONOSONDES

### The Digisonde 256

After the technical and operational success of the earlier digital ionosondes, the new Digisonde 256 concept was chosen to combine the simplicity of the Standard Digital Ionosonde DGS 128P with the flexibility and the fast preprocessing speed of the Universal Digisonde 128PS. Contained in a standard 7-inch high chassis, the Digisonde 256 includes a precise and fast

digital frequency synthesiser, a transceiver for the frequency range from 0.4 to 30 MHz with front-end tuning, a high-speed digitizer, a versatile multi-channel complex spectrum analyser and a complete timing unit. These subsystems are controlled by a built-in front-end microprocessor, which also programs the output circuits to optimize and format the data for display and recording on magnetic tape and hard copy.

Necessary peripheral equipment are a thermal dot printer and a wide-band pulse transmitter. A 2 x 7 antenna switch and the magnetic tape recorder are considered optional peripherals. Complete remote control of Digisonde 256 is possible and bistatic sounding between different ionosondes is a standard feature.

### A Summary of Specifications for Digisonde 256

#### RF Output

Frequency Sweep	: Logarithmic and linear 0.5-30 MHz; frequency hopping optional.
Sweep Duration	: 20 sec to several minutes depending on frequency sweep, step size and frequency repetition.
Frequency Synthesis	: Digital Synthesis in 5 kHz increments.
Frequency Steps	: Logarithmic sweep: 20, 40 or 80 steps per octave. Linear sweep: 5, 10, 25, 50, 100 or 200 kHz increments.
Frequency Optimization	: Three frequencies can be tested for minimum interference prior to transmission of each ionogram frequency.
Pulse Repetition Rate	: 50 Hz, 100 Hz, 200 Hz.
Frequency Repetition	: Four to 512 pulses at each frequency.
Pulse Width	: 66 $\mu$ s at 200 Hz; 66 or 133 $\mu$ s at 50 and 100 Hz
HF Phase Coding	: Interpulse and intrapulse pseudo-random 180° phase codes.
Pulse Peak Power	: 10 kW with ULCAR Transmitter.

#### RECEIVER

Band Width	: 20 kHz, optimum pulse reproduction; fast recovery.
Signal/Noise Ratio:	6 dB for 2 $\mu$ V input.
Input Protection	: Passive diode clipping; if no separate receiving antenna available, tap at dummy end of distributed transmitter power amplifier provides excellent receiver antenna input.

Dynamic Range : 64 dB + 42 dB switchable.  
 A G C : Digital in 6dB steps.  
 Diurnal Gain : Day, Twilight, Night sequence  
 Control : preprogrammed.

#### SIGNAL PROCESSING

Sixteen data integration channels shared for doppler, antenna configuration (incidence angle and polarisation) and range doubling.

Height Range : Selectable from 10 to 2680 km.  
 Range Bins : 128 or 256.  
 Height Resolution : 2.5, 5.0 or 10.0 km.  
 Spectral Integration : 2, 4, 8 or 16 spectral lines.  
 Wave Polarisation : 0 and X tagging (requires polarised receiving antennas).  
 Angle of Arrival : One to eight directions (requires seven element receiving array and Antenna Switch).  
 Dynamic Range : 90 dB  
 Amplitude Resolution : 3/16 or 3/32 dB.  
 Phase Resolution :  $1.4^\circ$ .

For a more complete technical description and further information, contact:

K Bibl  
 University of Lowell  
 Center for Atmospheric Research  
 450 Aiken Street  
 Lowell  
 Massachusetts 01854  
 U S A

#### The 610M1 Digital Ionosonde

The following data are abstracted from a circular issued by SRI International. INAG understands that the sounder is being redesigned for easier manufacture so that production models will probably show some changes in performance. The ionograms in the circular were unfortunately not suitable for reproduction here.

The 610M1 Digital Ionosonde is a small, light-weight, vertical incidence pulse sounder that can operate unattended at remote sites. The ionograms are digitised and recorded on magnetic recording medium, either tape or floppy disks. In its digitized form, the ionogram can be sent over telephone lines, or other public service or dedicated communications links.

The ionosonde is controlled by a clock-driven micro-processor and can be programmed to sound at a predetermined time or at specified intervals. In its standard configuration, it is programmed to sound on 256 frequencies, linearly or logarithmically spaced, over a range from 1.6 to 6, 10, 15 or 22 MHz.

The height resolution of the digitized ionogram is 75m. The maximum measureable height is 800 km.

A special five-pulse verification method is used to validate a return. At least three hits out of five at the same range and frequency must be obtained to have the return counted as an echo. An additional safeguard for avoiding interference is that the sounder "listens" on a frequency before transmitting. If the noise level at that frequency is above a specified level, the sounder does not transmit, but goes to the next assigned frequency, then samples the noise level once again. This technique results in an ionogram with a minimum of invalid data points and a sounder that minimizes interference to other HF users.

The sounder operates in conjunction with a cross-polarised delta antenna mounted on a 70-ft vertical mast. The two linearly-polarized inputs from the antenna are combined in a hybrid. The two outputs of the hybrid are sampled sequentially: one output is sampled for five successive pulses, then the second output is sampled for the next five pulses. The ionogram resulting from the first output corresponds to the ordinary ray returns, and the ionogram resulting from the second output corresponds to the extraordinary ray. These can be combined to give one ionogram with both components.

The use of solid-state circuitry, except for two vacuum tubes in the power amplifier, makes the sounder highly reliable.

Primarily designed for unattended operation, the 610M1 Ionosonde can be controlled either locally or remotely from a simple CRT terminal or by a computer. The digital ionogram data includes time of day, site location and the range and amplitude of up to three returns of both O and X data for each transmitted frequency. Although the ionosonde is designed to operate unattended and is normally supplied without a display, an optional on-line display can be provided.

FORTTRAN software packages are available for processing the ionosonde data. One of these packages separates the ordinary and extraordinary rays, and eliminates sporadic points and multiple-hop returns. A true-height profile can also be derived and plotted using a program, based upon the work of J E Titheridge, called POLAN.

#### Specifications

Frequency Range : 0.5 to 30 MHz  
 Number of Frequencies per Sweep (Maximum) : 256  
 Sweep Time (Max) : 56 s  
 Peak Pulse Power (variable) : 2 to 7 kW  
 Pulse Shape : Raised cosine  
 Pulse Width : 50  $\mu$ s  
 Pulse Interval : 5.33 ms  
 Height Resolution : 75 m  
 Maximum Height : 800 km

Sounding Inter-vals (selectable): 2, 5, 10, 15, 20, 30 and 60 minutes

Data Interface : RS-232

Power Requirement: 115/230 V 60 Hz  
200 W for 5-min sounding interval

Size : 30" high, 19.5" wide, 24" deep

Weight : 120 lb, approximately.

For further information, contact:

John C Schlobohm  
SRI International  
333 Ravenswood Avenue  
Menlo Park  
California 94025  
U S A

## 7. LOW LATITUDE PROBLEMS USING IONOGRAMS

by W R Piggott

### Introduction

There has been relatively little work done on the data from individual low latitude VI stations since the intensive analyses of Huancayo data in the 1930s and 1940s. Even after the IGY, it was relatively neglected in favour of high latitude studies. This is unfortunate as the geometry for interaction between electric fields, winds and the ionisation is very favourable near 45° dip (20-25° magnetic dip latitude) so that these forces may be expected to give relatively large changes in the position and shape of the layers near these latitudes. Most analyses have been concerned with a description of phenomena, but their implications on the morphology of the layers as a whole - and hence on the worldwide variations of electric field and winds - has not had much attention. In this note, I shall try to indicate some aspects of the phenomena which interest me and which I feel might form growing points for new work.

It is well known that lunar effects are abnormally large in the magnetic tropics and much work has been published on amplitude and phase as a function of latitude. Why do these occur and what are the implications for the world-wide potential systems which are generated by the tidal movements? Are we getting the most out of the available data? We have to break away from classical mid-latitude thinking.

### Lunar Stratification at Very Low Latitudes

The lunar stratification, in which at certain phases of the moon part of the F layer ionisation is redistributed to give an F1.5 ledge and eventually disappears above hmF2, has been known as an anomaly for over 40 years. An example was given in the IGY Atlas of Ionograms (Wright and Knecht, 1957). The phenomenon is found occasionally at most stations inside the peaks of the equatorial F2 layer anomaly (Appleton anomaly).

In my view, we should reconsider this phenomenon which brings out one of the ways in which the low latitude ionosphere is fundamentally different to that on mid-latitudes. At low latitudes, the scale heights  $H$ ,  $H = KT/mg'$  are very large because the effective value of  $g'$ , parallel to the magnetic field, is very small. If  $D$  is the angle of dip, then  $g' = g \sin D$ . For these conditions, the horizontal variation of maximum electron density is more important than the vertical and the shape of the  $N(h)$  curve depends on the variations of NmF2 (or foF2) and hmF2 with distance and the angle of dip  $D$ . The apparent vertical motion of hmF2 and the lunar stratification is thus an effect of the movement of a peak in NmF2 horizontally. Incidentally, this is also one of the reasons why low latitude ionograms are often a different shape to those found at mid-latitudes and why near-linear  $N(h)$  distributions are so often found. Nearer the Appleton peaks in NmF2, the surfaces of constant ionization  $N$  are usually seriously tilted (see Handbook letter Y) giving hmF2 too high, M3000F2 too low and difficulties in interpreting the  $h'f$  pattern for  $N(h)$  analysis.

Since the magnetic field is nearly horizontal, horizontal winds can move ionisation horizontally very easily, the changes in layer shape depending on where  $\text{div}(Nv)$  is a maximum and how the position of this maximum changes in latitude. This type of argument is well known to incoherent scatter investigators studying equatorial spread-F bubbles. The principle of least action implies that electric fields may be generated when this is easier than moving the ionisation directly.

### Moving Ridges of Ionisation

The main features of the Appleton anomaly appear to be fairly well understood theoretically, though the changes in its behaviour with longitude are still larger than expected. However, the anomaly is seldom simple, lunar stratification being one of the omitted terms. Ridges of ionisation also appear to move from near the auroral zone to the equatorial anomaly peak latitudes, but have been little studied. For these foF2 and thus NmF2 increases, but the layer gets thinner and usually lower so that  $\int Ndh$  is more or less unaltered. For these conditions, there are marked differences between changes in foF2 and in the total ionisation content seen by satellite beacon experiments.

At the low latitude stations showing such phenomena, the quiet day variations of foF2 are often very different on different days of the month and there are often large delayed, and occasionally immediate, storm perturbations. Unlike other latitudes, the median diurnal variation of foF2 does not resemble any of the more commonly occurring patterns so that the classical methods of study are inapplicable. In view of the large lunar effects at low latitudes, it may well be worthwhile to re-examine the data sorting it according to lunar phase. So far as I know, this has not been attempted. Of course, if this suggestion is true, storm day variations may also depend on lunar phase. Note that solar modifications of tidal forces at low latitudes appear to be large.

### Low Es at Low Latitudes

Low Es is very common at stations in the tropical zones. Sequences in which it moves from about 100-105 km to 85 km or even lower are fairly common. At some stations, e.g. Wuchang, there are strong diurnal and

lunar changes in both the number of occurrences at a given hour and the heights at which the low Es is seen. A superficial inspection of the data suggests that these changes may well be linked with the changes in F2 behaviour mentioned above, in which case the possibilities would be very exciting. At middle latitudes the effects are much smaller and often confused by z-mode reflections from the E layer. This looks like a profitable field, even for single station studies and I would be surprised if a comparison of such studies did not show a fairly direct change with latitude and longitude. At Wuchang, there are remarkably large changes in the height of low Es at night with periods near 14 and 28 days. Are these present elsewhere? It should be noted that totally reflecting low Es has large effects on  $f_{min}$  as much of the absorption in the D and lower E layers can be above it. This also, of course, affects A1 absorption measurements which are measured on frequencies reflected from a low Es layer. In my view, such data need reconsideration, e.g. it may well be that the absorption peaks near  $30^\circ$  magnetic latitude have been seriously underestimated. At present, there is a controversy since magnetoionic effects could cause the observed maximum whereas rockets show an actual increase in the electron density of the D region in this zone.

#### Particle Effects at Low Latitudes

I have commented before that typical high latitude, auroral zone phenomena are quite common, but less intense, at surprisingly low latitudes. Satellite data show that there is a precipitation zone near  $30^\circ$  magnetic latitude, but the ionospheric community does not appear to have looked for the corresponding effects in the ionosphere. In recent visits to stations, I have seen such effects in even relatively small samples of the station's data. Why have they not been described in the literature? I think it is because too many low latitude students do not realise that the special features of low latitudes can only be studied using low latitude data. They look for phenomena formed elsewhere instead of new local phenomena.

On ionograms, I have seen at several stations one or more of the following:-

- a. increases in absorption at night ( $f_{min}$  and loss of x-mode) lasting for 15 minutes to about an hour on some nights showing magnetic activity (studied at Wuchang).
- b. increases in the daytime absorption ( $f_{min}$  increases) on the days following such events and, in sunspot minimum years, when the normal absorption is low, about 3 days after major magnetic storms (studied at Wuchang).
- c. Es-s, Es-a, and a form of Es-q associated with local magnetic activity at night.
- d. low Es which appears to be associated with storm perturbations of the F2 layer, possibly with a superimposed lunar dependency which makes it consistent at first sight.

Thus, there appears to be a wide open field for active study of ionograms both to show what is really happening and to provide a ground based monitoring on a day to day basis of particle precipitation at low latitudes.

#### Operational Implications

Many new stations have been set up to provide operational data for radio communication problems. There are special features of the low latitude ionosphere which should be taken into account. Thus, for example, where low Es is common, it greatly modifies the absorption losses at MF and the lower end of the HF band, giving much more skywave than would be expected from propagation off the F2 layer. Owing to its low height, the MUF factor of low Es can be very large, 5-7, giving strong reflections regularly where it is common between 1000 and 1500 km even in the 10 MHz - 25 MHz band.

While conventional analysis of F2 propagation applies at short ranges, e.g. up to a few hundred kilometres, the large gradients associated with the equatorial anomaly and the moving ridges make skew propagation from such structures dominant. Thus, the narrow clefts lasting up to an hour or so in the F2 layer f-plots have no effect on oblique propagation and the MUF is determined by the maximum foF2 available between the ends of the hop (for one hop propagation). Most practical work at low latitudes has stressed the occasions when the oblique MUF agreed with the theoretical and not the fact that propagation is often more regular than would be expected from the statistics of foF2.

#### 8. DERIVING THE M(3000) FACTOR FROM THE x-TRACE

by R W Smith, Rutherford Appleton Laboratory, UK

The standard transmission curve details given on page 23 of UAG-23A have been derived from ordinary wave propagation theory and consequently the M(3000) factors should be measured from the ordinary trace. If only part of the o-trace is present and the overlay curve can be made tangential to it, a numerical M(3000) may be obtained by using foF2 derived from fxF2. If the o-trace is missing or the overlay cannot be used, the appropriate descriptive letter is used in place of a number. Much missing data could be made numerical if the x-trace could be used to give M(3000).

To assess the errors involved in using the x-trace, M(3000) factors have been derived from both o- and x-traces from a series of Slough ionograms which showed both components clearly. The average results for o- and x- from this small sample proved to be the same and the maximum difference between corresponding values was 0.10.

This analysis suggests that for most of the time in temperate latitudes, it should be possible to obtain a numerical value of M(3000) described by X (and possibly qualified by U) from ionograms with a missing or unusable o-trace.



Chairman's Note

9. AN IONOSONDE TEST UNIT

It is easy to show that, if the extraordinary trace has the same shape as the ordinary trace and is at the same virtual height near the tangent point of the MUF slider or overlay, the MUF factor deduced from the o-mode and foF2 must be identical with that for the x-mode and fxF2 (using fxF2 as the appropriate critical frequency). This is purely a matter of geometry, the factor depends on the virtual height of the tangent point and the critical frequency of the trace. Provided that fxF2 is not too near fB, the shape of the x-trace is remarkably similar to that of the o-trace when the ionosphere is horizontal. However, the x-trace must always be slightly higher than the o-trace when any under-lying ionisation is present below the reflection height. The difference becomes great when foF2 approaches foF1 or foF2 approaches fB, the electron gyro-frequency. In practice, as shown by Mr Smith's analysis, the error is often less than the experimental error for a considerable range of practical conditions. Probably, the residual tilts cause more scatter than the systematic error so that it cannot be detected. It would be interesting to repeat this test at other stations since it is likely that the result is fairly general. Note that the difference in height of the tangent point of the MUF slider decreases as foF2 increases - the main practical problem is to establish rules for when the method breaks down, i.e. how near foF2 can be to foF1 or foF2 to fB for day or night conditions. Roughly an increase in virtual height at the tangent point of 5 km will make M(3000) too small by 0.05. INAG would like to receive further communications on this topic and suggestions for limit values of foF2/foF1 and of foF2/fB at night in temperate latitudes to guide any workers who wish to adopt this technique. If it proves of real value, consideration will be given to make an INAG recommendation and rules in due course.

by K. Feldmesser, Rutherford Appleton Laboratory, UK

As most ionosphericists know from experience, the ionosphere also obeys its own "Parkinson's Law" which can be stated thus: "Unusual ionospheric phenomena tend to coincide with periods when ionosonde performance is in doubt" and its corollary: "A sudden ionospheric disturbance often occurs within half an hour of any major adjustment to the ionosonde".

Having been caught out in my early days in the subject on two occasions trying to restore the echo trace on the ionosonde during an S.I.D., I decided that what was needed was an instrument akin to the 'echo box' of the radar engineer which would allow a test of equipment performance by simulating an echo electronically.

One important design consideration was that the device should be capable of testing the system of the ionosonde overall, including the antennae, its feeders, line switches, etc., since in the exposed location of the Outer Hebrides where the problems first arose, the inclement weather often subjects the aerial systems to substantial stress.

This implies that the device would involve a miniature transmitter capable of radiating a brief pulse of radio frequency energy in the vicinity of the ionosonde antenna, synchronised with the ionosonde receiver so as to provide a reference echo signal. An instrument designed on these lines has worked well for several years, being used as part of a weekly preventive maintenance check.

In addition to providing a signal into a calibration antenna, the unit also produces pulses at the intermediate frequency and a video pulse allowing comprehensive testing of the receiver circuits.

A block diagram shows the concept:

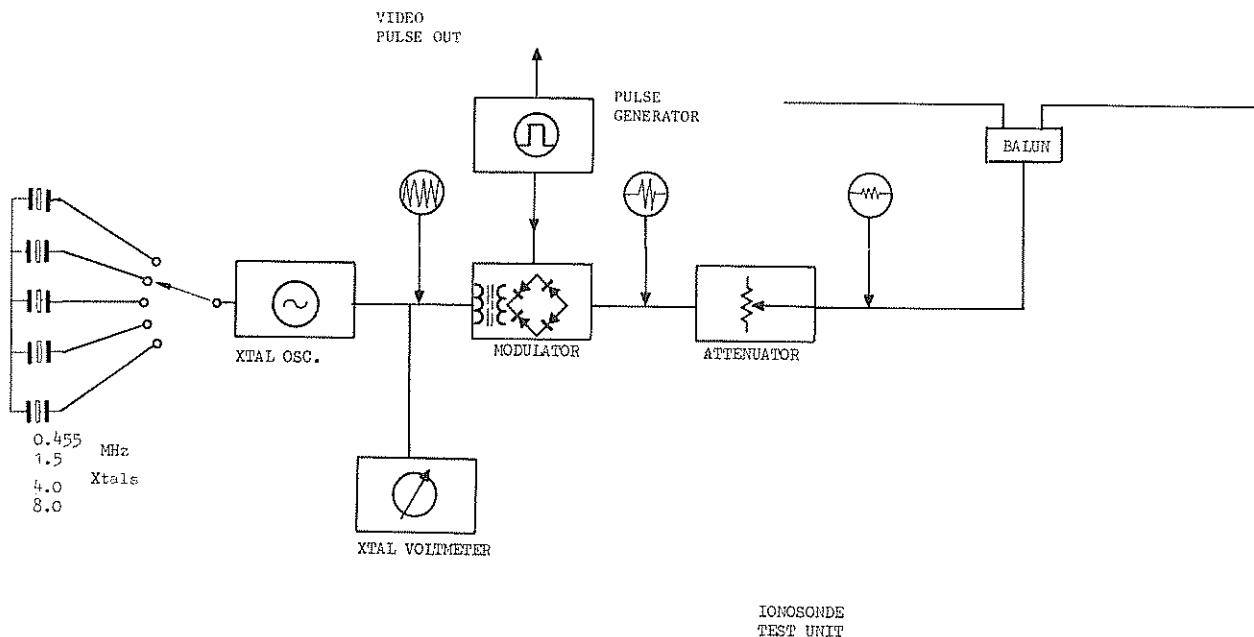

A crystal oscillator (XTAL OSC) contains a set of crystals one for each band of the ionosonde, plus an extra position for another spot frequency. The c.w. signal is monitored by a crystal voltmeter and converted to radio frequency pulses of measured amplitude in the modulator.

The output signal is set to the required level by the attenuator then either passed to the calibration antenna or injected into the receiver at various points in the signal path. The ionosonde is tuned to the selected crystal frequency and the received pulse displayed. The attenuator is set to attain a standard amplitude of displayed pulse and each band of the receiver is tested in this way. The ionosonde transmitter is of course not required for these tests. These tests, together with a measurement of transmitter current into the antenna when the ionosonde is working normally provide a fairly comprehensive check on performance rapidly and conveniently. No modifications to the ionosonde are required when testing with a radiated signal and the provision of co-axial connectors at the injection points are the only modifications needed for the other tests.

The system has potential for calibrating one ionosonde against another since the very portable test unit can transmit a signal of accurately repeatable amplitude and frequency. If it is used with an identical calibration antenna at the same position with respect to the two ionosonde antennae it will provide accurate comparison levels. This feature could improve inter-comparison between ionosondes world wide and provide reference levels even between instruments of different design.

#### 10. A DAYTIME CROSSING OF THE AURORAL OVAL AT HALLEY BAY, ANTARCTICA

by M. Pinnock, British Antarctic Survey, Cambridge, UK

The line drawings traced from a sequence of ionograms show the signature of a daytime crossing of the auroral oval. The unusual feature of this event is that it was recorded at Halley Bay, Antarctica ( $76^{\circ}\text{S}$ ,  $27^{\circ}\text{W}$ ; geomagnetic latitude  $-66^{\circ}$ ) on the 19th December 1980. Thus, the auroral oval was observed at a much lower magnetic latitude than would normally be expected near mid-day. However, the event did occur when magnetic activity was very high with Ks values (see UAG-23, p 300) for the period of 8 and 7. The preferred scaled values for some parameters are given in the Table.

The event starts at 1230 LT with the appearance of two oblique traces, one near 400 km at a frequency of 8MHz, the other above 500 km between 5 and 6MHz. The shape of the lower frequency oblique trace is repeated on the 1245 LT ionogram, but at a much lower height, indicating that the reflecting region has moved closer to Halley Bay, probably by about 150 km. The shape of the oblique traces at 1230 LT shows them to be F region reflections from field aligned irregularities (see UAG-23A page 44) rather than from Es-a layers at a considerable distance from overhead. The key feature for this identification is the group retardation at the low frequency end of the oblique traces which occurs at frequencies immediately above foF1 and foF2. This ionogram pattern indicates that there is a large increase in the F-region electron concentration near Halley Bay.

In Figure 1, possible contours of equal ionisation in the vicinity of the station are shown, together with ray paths for three frequencies 4.5MHz (i.e. foF1), 6.5MHz and 7.5MHz (i.e. foF2). For Ray 1, the refraction is sufficiently great for the wave to become perpendicular to the irregularity, thus be reflected back to Halley Bay. However, with increasing frequency above foF1, refraction becomes insufficient to produce a returned echo (Ray 2). This accounts for the sharp cut off at 6.3MHz on the oblique trace and is also the reason why no oblique echoes are observed below foF1. Refraction again becomes significant in the vicinity of hmF2 (Ray 3) and the conditions for a returned echo are met for the frequency range 7.5MHz to 8.7MHz.

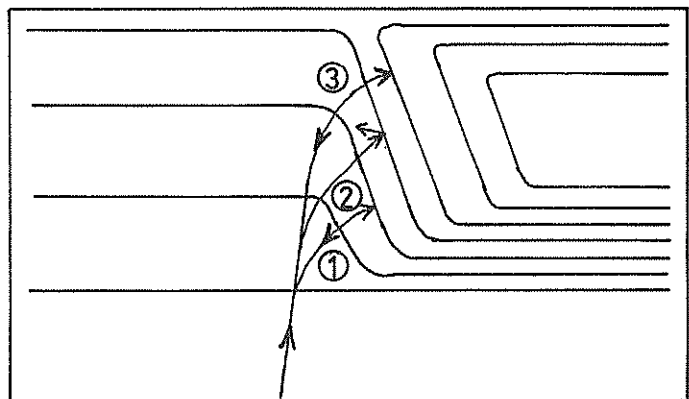

Figure 1. Possible iso-ionic contours and ray paths for three frequencies, 1. 4.5MHz, 2. 6.5MHz and 3. 7.5MHz

As the large irregularity in electron concentration approaches the station, the geometry for refraction changes significantly resulting in the rapid change of pattern of the oblique layers between 1230 and 1245LT.

At 1300 LT and 1305 LT, both the character of the oblique traces above 5MHz and their virtual height have changed substantially and it is suggested that they are Es-a traces seen at oblique incidence. If the virtual height (i.e. slant range) is 200 km, and it is assumed that the overhead virtual height would be 120 km, then the Es-a trace is 160 km away from Halley Bay. Other features have also changed at this time. There is the first indication of the presence of an Es-s trace rising from foE. This is partially masked by a small Es-c layer with foEs near 4MHz. The F1 layer shows the presence of a large disturbance and the amount of Spread-F near foF2 has increased.

By 1315, F1 lacuna has developed and the presence of Es-s is much clearer. The rise in virtual height with frequency of the trace appears less than is normally seen. The strengthening of the Es-c layer at 1330 LT may suggest that the F1 layer is being blanketed, but the sequence, including the 1345 LT ionogram, suggests lacuna is the correct interpretation.

From 1305 LT through to 1345 LT the virtual height of the F2 layer continually rises, but foF2 for this period falls only by 2MHz and is still well above the expected value for foF1 for this time (4.5MHz). This sequence leads to a very difficult question. What has happened to the F2 layer at 1400 and 1415LT (only one ionogram is

Sequence of Ionograms from Halley Bay, 19 December 1980

Local time which is UT-2 hours shown in top left-hand corner of each ionogram.

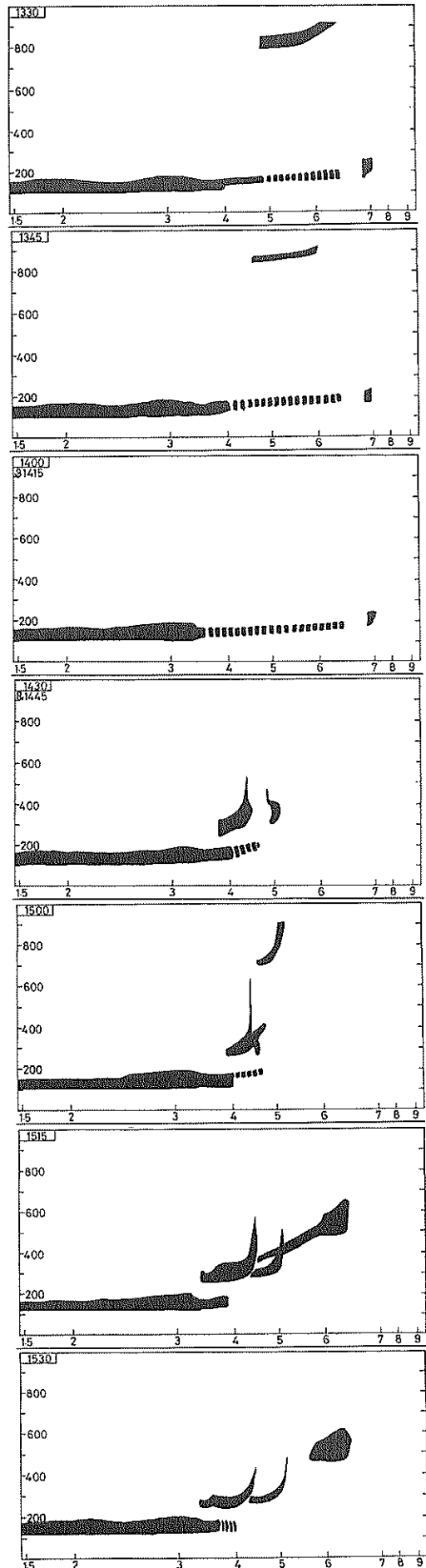
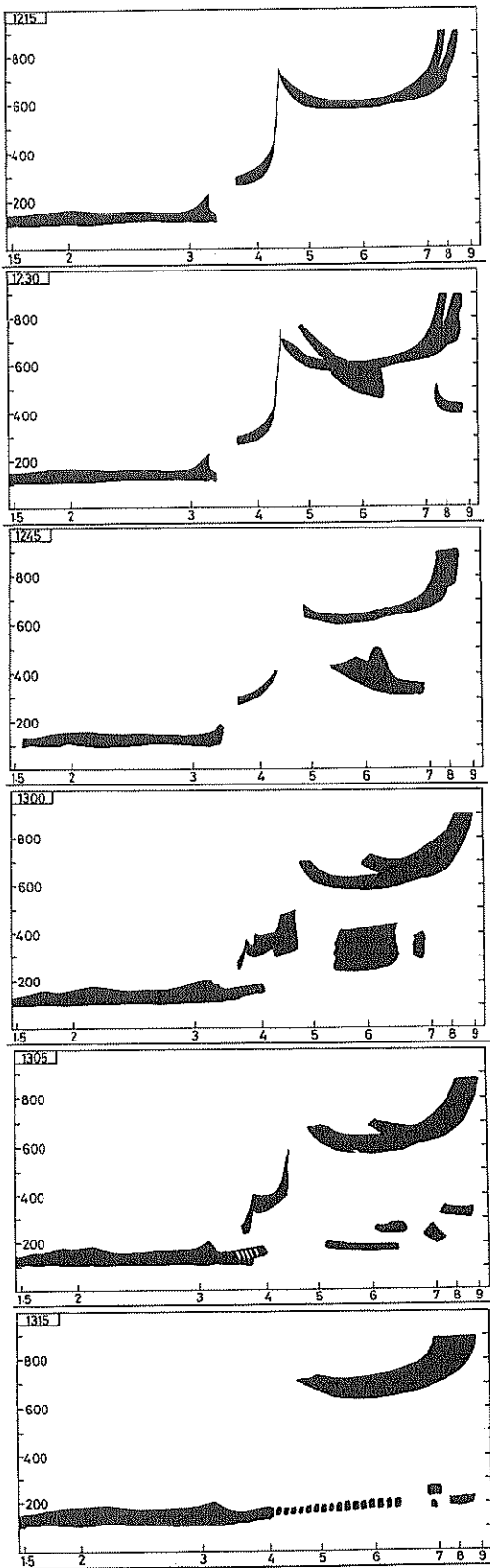

Preferred Scaled Values

	foF2	fxI	foF1	h'f	h'F2	Es Types	foEs	foE	fbEs
1215	075	082-X	450	260	570	-	-	340-R	034EG
1230	075	087-P	450	260	570	-	-	340-R	034EG
1245	073UF	083	460-R	260	600	-	-	340-R	034EG
1300	083UF	039	450	240-H	580	C1,S	038	340-A	036
1305	082UF	090	460	230-H	570	C1,S	038	340-A	038
1315	070UF	086	450UY	Y	620	C1,S	040	340-A	040UY
1330	062UF	0690B	Y	Y	800	C1,S	050	340-A	050UY
1345	0620UR	0680B	Y	Y	850	C1,S	040	340-A	040UY
1400 and 1415	Y	Y	Y	Y	Y	C1,S	036	340-A	036UY
1430 and 1445	G	052-X	440-Y	230	G	C1,S	041	340-A	037
1500	052	0580X	450	250	700	C1,S	040	340-A	038
1515	G	064-P	450	240	G	C1	038	340-A	035
1530	G	064-P	460	220	G	C1	037	330-A	035

shown) as the two are identical? There are three possible interpretations. These are:

- the F2 region has risen further, so it is not seen in the normal height range (letter W),
- foF2 has fallen rapidly into a G condition (letter G),
- total lacuna is present (letter Y).

The ionograms at 1430 and 1445LT (again only one is shown) do not help substantially. The F1 shows a slight nose (a more severe example for the F2 layer is given in UAG-23A, page 44). An Es-s trace is again present, but there is little doubt that the F2 layer is in a G condition at this time. Guidance on use of G during lacuna (UAG-23A, page 93) does not cover the case where foF2 is present before the lacuna, but there

is a G condition after lacuna. As there is insufficient evidence to choose between the alternative scaling for foF2 at 1400 and 1415LT, letter Y has been selected because it is the best indicator that something unusual is occurring at Halley Bay and deserves further study.

For the next few hours from 1500 LT, the F2 layer remains in, or close to, a G condition. The unusual feature for this period is the oblique F2 region trace at 1515LT reflecting from a field aligned structure (see UAG-23A, page 49). The presence of this spur-type trace is indicated by the descriptive letter P with fxI (UAG-23A, page 62).

The character of the sequence and the occurrence centred about local magnetic noon (1330 LT) suggests a close approach or a crossing of the auroral oval in the vicinity of the polar cusp. The oblique layers from

1230 LT are similar in appearance to those used by Ungstrup et al (1975) for identifying the polar cusp. There is an enhancement at 1245 - 1300 LT of foF2 which is frequently reported under the polar cusp resulting from the precipitation of soft charged particles.

The development of the lacuna from 1315 LT is most interesting as it is attended by a rapid rise in virtual height of the F2 layer. It has been suggested that Es-s occurs when there is a very large electric field in the lower ionosphere. This electric field should cause a large change in the virtual height of the F layer, either upwards or downwards depending upon the direction of the field. However, such movements of the F layer are not normally reported.

There is some evidence of a reduction in both range and frequency Spread-F on the F region traces preceding the total lacuna. This suggests that for this example the explanation put forward by Sylvain et al (1978) for the interpretation of lacuna is possible. They suggest that radio waves reflected from structures some distance from the ionosonde will suffer considerably more attenuation (up to 30dB) than those reflecting from near overhead; the obliquely propagating signals suffer more absorption in the D region and are less efficiently received by vertical antennae. For this to occur, and for the overhead echo to be absent, a large gradient in electron concentration must exist, such as that associated with the polar cusp.

The oblique layer present from 1515LT (and the next few hours) is most likely a reflection from a ridge of ionisation in the dayside auroral oval, the station maintaining approximately a constant distance and orientation to the feature.

It is suggested that the sequence offers a good example of the difficulty in distinguishing between the use of G and Y when scaling the absence of an F2 layer.

#### References

Sylvain et al, Planet. Space Sci., Vol. 26, 785-799, 1978.

Ungstrup et al, Geophysical Research Letters, Vol. 2, 345-348, 1975.

### 11. KEL AEROSPACE PTY LTD PRODUCTS

#### The KEL-46 - A Semi-Automatic Digitizing System

Most Vertical Incidence ionospheric stations have a need for their scaled ionospheric data to be in computer-compatible form, especially hourly data which are exchanged internationally. Semi-automatic digitizing is currently the most efficient process for these stations because it enables the use of many modern digital storage and transmission techniques at the same time as utilizing the experience and judgement capabilities which have been built up over many years by the scaling personnel. The principle of semi-automatic digitizing is that the scaler is required to interpret the trace and to indicate the actual position of each parameter for input into the system.

Semi-automatic digitizing systems have been around for many years. Some of the early ones used a system of pulleys connected to a mechanically supported cross-hair which could be positioned anywhere on a plan-table. The ionogram was projected down onto the plan-table, the cross-hair was located at the correct position by the scaler, a button was pressed and the co-ordinates would be automatically interpreted. The qualifying and descriptive letters would then be entered via a keyboard, as would be the day/hour/station information. This information would then be stored, sometimes on punched paper tape, or on punched cards. There was little or no 'standardization' of the storage medium, or the storage formats used by the various stations in the world that originally developed semi-automatic digitizing systems.

KEL Aerospace Pty Ltd currently market a semi-automatic scaling system called the KEL-46. KEL-46 Data Analyser Systems have already been sold in countries including Indonesia, Venezuela, Nigeria, Iraq and Korea and other groups have already decided to install this system during 1983. Each country will therefore be producing identically formatted digital data of monthly ionospheric parameters. A Monthly Data Disc will be a 5¼ inch floppy disc with up to 31 days of 24 separate hourly records of up to 19 ionospheric parameters, including qualifying and descriptive letters. Each hourly record of approximately 160 bytes of data will also contain the station identification and the year/day/time information. The data are in standard ASCII text files and can be transmitted through world data networks at low cost, once the correct communications interfaces and protocols have been set up at each end. The KEL-46 must be upgraded to enable it to act as an intelligent terminal, capable of transmitting and/or receiving such data. This upgrade may be done in the factory prior to shipment, or it may be done in the field at a later date. The floppy discs can also be easily duplicated using the standard KEL-46 so that copies can be mailed to other groups

The KEL-46 Data Analyser System includes a 16mm projector, a high resolution graphics tablet, a 5¼" floppy disc drive, an 'interactive' microprocessor system and a comprehensive 'entry' software package. All data entry is achieved using the stylus on the graphics tablet. No separate keyboard entry is necessary.

The system is designed to be used for entering one month of scaled hourly ionospheric data onto a single floppy disc. A backup can be made from the disc so that a copy is retained at the scaling location whilst the data are sent to the 'Central Processing Facility', thus reducing the risk of loss of scaled data.

Optional extras include an intelligent-terminal upgrade with a modem, serial communications interface, communications software and a full ASCII keyboard. A printer option can also be supplied and would include a serial printer interface and a 180 cps graphics printer. An upgraded software package would also be required and would enable printing of individual monthly reports.

It is assumed that at the 'Central Processing Facility' there will be both the hardware and the programming capability to read the data which have been stored on the 5¼" floppy discs. This may not be so in all cases and KEL Aerospace is about to release the 'KEL-47 Central Processing System' which can store ten years of scaled hourly data, with simple Data Base Management software and a printer for approximately A\$23,000. This

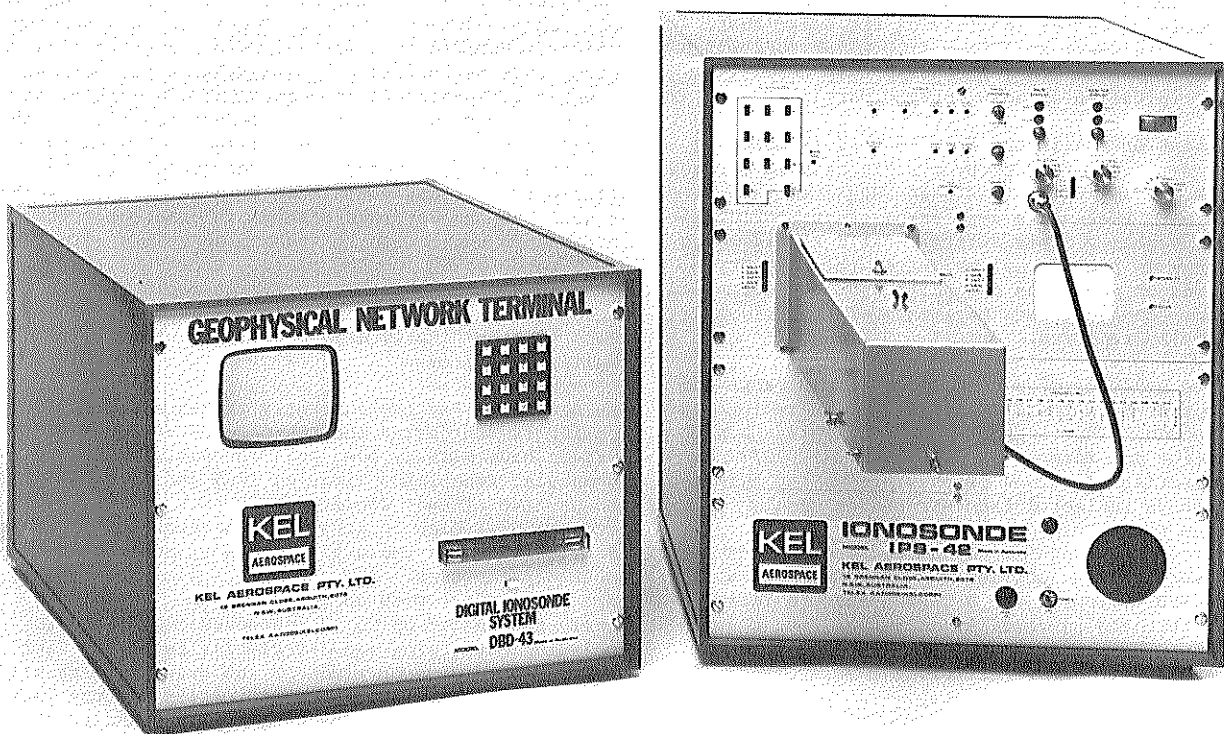

system will initially read and store the monthly data and will print simple monthly reports of day/hour values for each parameter through the month as well as median values for each day/hour table and a monthly graphical summary of some median values. Future software packages will enable searches to be made through the data base for various combinations of data as required.

The DBD-43 Digital Add-On System, for the IPS-42 Ionosonde

The KEL Aerospace DBD-43 Digital Add-On System for the IPS-42 ionosonde is a design which has evolved over the last four years following the design concept of the original DBD-42 and the many design changes and technical improvements that resulted from that initial project.

The DBD-43 system represents just one special application of the KEL Aerospace general purpose 'Geophysical Terminal'.

A versatile Geophysical Data Gathering Terminal must have the following capabilities . . .

- High speed data collection
- Large volume of data storage
- Multiple simultaneous monitoring
- Versatile communicating capability
- Unmanned operation
- Remote control
- Real time data display (local and remote)

- Data processing
- Data packing

The KEL Aerospace 'Geophysical Terminal' can be used in local scientific applications and is also a valuable terminal for national and international networks of ionospheric, seismic and meteorological stations.

For more information on these and other KEL Aerospace products, contact:

KEL Aerospace Pty Ltd  
12 Brennan Close  
Asquith  
New South Wales 2078  
Australia

# International Geophysical Calendar for 1983

	S	M	T	W	T	F	S		S	M	T	W	T	F	S	
							1		26	27	28	29	30	1	2	
	2	3	4	5	6	7	8		3	4	5	6	7	8	9	
	9	10	(11)	(12) <sup>**</sup>	(13) <sup>*</sup>	14	15		10	11	(12) <sup>*</sup>	(13) <sup>**</sup>	(14)	15	16	JULY
JANUARY	16	17	18	19	20	21	22		17	18	19	20	21	22	23	
	23	24	25	26	27	28	29		24	25	26	27	28	29	30	
	30	31	1	2	3	4	5		31	1	2	3	4	5	6	
	6	7	8	9	10	11	12		7	8	9	10	11	12	13	
FEBRUARY	13	14	(15) <sup>*</sup>	(16) <sup>**</sup>	(17) <sup>*</sup>	18	19		14	15	(16) <sup>*</sup>	(17) <sup>**</sup>	(18)	19	20	AUGUST
	20	21	22	23	24	25	26		21	22	23	24	25	26	27	
	27	28	1	2	3	4	5		28	29	30	31	1	2	3	
	6	7	8	9	10	11	12		4	5	6	7	8	9	10	
MARCH	(13)	14	(15)	(16) <sup>**</sup>	(17) <sup>*</sup>	18	19		(11)	12	(13) <sup>*</sup>	(14) <sup>**</sup>	(15)	16	17	SEPTEMBER
	20	21	22	23	24	25	26		18	19	20	21	22	23	24	
	27	28	29	30	31	1	2		25	26	27	28	29	30	1	
	3	4	5	6	7	8	9		2	3	4	5 <sup>**</sup>	6 <sup>*</sup>	7	8	
APRIL	10	11	(12)	(13) <sup>**</sup>	(14) <sup>*</sup>	15	16		9	10	11	12	13	14	15	OCTOBER
	17	18	19	20	21	22	23		16	17	(18)	(19)	(20)	21	22	
	24	25	26	27	28	29	30		23	24	25	26	27	28	29	
	1	2	3	4	5	6	7		30	31	1	2 <sup>**</sup>	3 <sup>*</sup>	4	5	
	8	9	10	11	12	13	14		6	7	8	9	10	11	12	
MAY	15	16	(17) <sup>*</sup>	(18) <sup>**</sup>	(19) <sup>*</sup>	20	21		13	14	(15)	(16)	(17)	18	19	NOVEMBER
	22	23	24	25	26	27	28		20	21	22	23	24	25	26	
	29	30	31	1	2	3	4		27	28	29	30	1	2	3	
	5	6	7	8	9	10	(11)		4	5	6	7	8	9	10	
JUNE	(12)	13	(14) <sup>**</sup>	(15) <sup>**</sup>	(16) <sup>**</sup>	17	18		(11)	12	(13) <sup>*</sup>	(14) <sup>**</sup>	(15)	16	17	DECEMBER
	19	20	21	22	23	24	25		18	19	20	21	22	23	24	
	26	27	28	29	30	1	2		25	26	27	28	29	30	31	
	S	M	T	W	T	F	S		1	2	3	4	5	6	7	
									8	9	10 <sup>*</sup>	11 <sup>*</sup>	12	13	14	
									15	16	(17)	(18)	(19)	20	21	1984
									22	23	24	25	26	27	28	JANUARY
									29	30	31					
									S	M	T	W	T	F	S	

(13) Regular World Day (RWD)

(12) Priority Regular World Day (PRWD)

(16) Quarterly World Day (QWD)  
also a PRWD and RWD

(5) Regular Geophysical Day (RGD)

(7-8) World Geophysical Interval (WGI)

12\* Incoherent Scatter Coordinated  
Observation Day and Coordinated  
Tidal Observation Day

(11) Day of Solar Eclipse

(13-14) Airglow and Aurora Period

13\* Dark Moon Geophysical Day (DMGD)

**NOTES:**

1. Days with unusual meteor shower activity are: Northern Hemisphere Jan 3, 4; Apr 22, 23; May 3-6; Jun 8-12, 23, 24; Jul 27-30; Aug 11-14; Oct 20-23; Nov 2, 3, 17; Dec 13-15, 22, 23, 1983. Southern Hemisphere May 3-6; Jun 8-12, 23, 24; Jul 26-31; Oct 20-23; Nov 2, 3, 17; Dec 5, 6, 13-15, 1983.

2. Middle Atmosphere Program (MAP) began 1 Jan 1982 and runs through 1985.

OPERATIONAL EDITION, September 1982

## EXPLANATIONS

This Calendar continues the series begun for the IGY years 1957-58, and is issued annually to recommend dates for solar and geophysical observations which cannot be carried out continuously. Thus, the amount of observational data in existence tends to be larger on Calendar days. The recommendations on data reduction and especially the flow of data to World Data Centers (WDCs) in many instances emphasize Calendar days. The Calendar is prepared by the International Ursigram and World Days Service (IUWDS) with the advice of spokesmen for the various scientific disciplines. For greater detail concerning explanations or recommendations your attention is called to information published periodically in IAGA News, IUGG Chronicle, URSI Information Bulletin or other scientific journals.

The definitions of the designated days remain as described on previous Calendars. Universal Time (UT) is the standard time for all world days. Regular Geophysical Days (RGD) are each Wednesday. Regular World Days (RWD) are three consecutive days each month, always Tuesday, Wednesday and Thursday near the middle of the month. Priority Regular World Days (PRWD) are the RWD which fall on Wednesdays. Quarterly World Days (QWD) are one day each quarter and are the PRWD which fall in the World Geophysical Intervals (WGI). The WGI are fourteen consecutive days in each season, beginning on Monday of the selected month, and normally shift from year to year. In 1983 the WGI will be March, June, September and December.

The Solar Eclipses are June 11 (total) beginning in the southern part of the Indian Ocean, crossing Indonesia, ending in the Pacific Ocean between the New Hebrides and the Loyalty Islands; December 4 (annular) beginning in the Atlantic Ocean northeast of the Bermuda Islands, passing south of the Cape Verde Islands, entering Africa just south of the equator, and ending at the extreme northeastern part of Africa.

Meteor Showers (selected by P.M. Millman, Ottawa) include important visual showers and also unusual showers observable mainly by radio and radar techniques. The dates for Northern Hemisphere meteor showers are: Jan 3, 4; Apr 22, 23; May 3-6; Jun 8-12, 23, 24; Jul 27-30; Aug 11-14; Oct 20-23; Nov 2, 3, 17; Dec 13-15, 22, 23, 1983. The dates for Southern Hemisphere meteor showers are: May 3-6; Jun 8-12, 23, 24; Jul 25-31; Oct 20-23; Nov 2, 3, 17; Dec 5, 6, 13-15, 1983. Note that the meteor showers that come in the first week of May and the third week in October are of particular interest (fragments of Halley's comet) because of the approach of Halley's comet in 1986.

The occurrence of unusual solar or geophysical conditions is announced or forecast by the IUWDS through various types of geophysical "Alerts" which are widely distributed by telegram and radio broadcast on a current schedule. Stratospheric warnings (STRATWARM) are also designated. The meteorological telecommunications network coordinated by WMO carries these worldwide Alerts once daily soon after 0400 UT. For definitions of Alerts see IUWDS "Synoptic Codes for Solar and Geophysical Data, Third Revised Edition 1973" and its amendments. Retrospective World Intervals are selected and announced by MONSEE and elsewhere to provide additional analyzed data for particular events studied in the ICSU Scientific Committee on Solar-Terrestrial Physics (SCOSTEP) programs.

RECOMMENDED SCIENTIFIC PROGRAMS  
PLANNING EDITION

(The following material was reviewed in 1982 by spokesmen of IAGA, WMO and URSI as suitable for coordinated geophysical programs in 1983.)

**Airglow and Aurora Phenomena.** Airglow and auroral observatories operate with their full capacity around the New Moon periods. However, for progress in understanding the mechanism of inter alia, low latitude aurora, the coordinated use of all available techniques, optical and radio, from the ground and in space is required. Thus, for the airglow and aurora 7-day periods on the Calendar, ionosonde, incoherent scatter, special satellite or balloon observations, etc., are especially encouraged. Periods of approximately two weeks' duration centered on the New Moon are proposed for high resolution of ionospheric, auroral and magnetospheric observations at high latitudes during northern winter.

**Atmospheric Electricity.** Not-continuous measurements and data reduction for continuous measurements of atmospheric electric current density, field, conductivities, space charges, ion number densities, ionosphere potentials, condensation nuclei, etc., both at ground as well as with radiosondes, aircraft, rockets; should be done with first priority on the RGD each Wednesday, beginning on 5 January 1983 at 1800 UT, 12 January at 0600 UT, 19 January at 0600 UT, 26 January at 1200 UT, etc. (beginning hour shifts six hours each week, but is always on Wednesday). Minimum program is at the same time on PRWD beginning with 12 January at 0600 UT. Data reduction for continuous measurements should be extended, if possible, to cover at least the full RGD including, in addition, at least 6 hours prior to indicated beginning time. Measurements prohibited by bad weather should be done 24 hours later. Results on serics and ELF are wanted with first priority for the same hours, short-period measurements centered around the minutes 35-50 of the hours indicated. Priority Weeks are the weeks which contain a PRWD; minimum priority weeks are the ones with a QWD. The World Data Centre for Atmospheric Electricity, 7 Karbysheva, Leningrad 194018, USSR, is the collection point for data and information on measurements.

**Geomagnetic Phenomena.** It has always been a leading principle for geomagnetic observatories that operations should be as continuous as possible and the great majority of stations undertake the same program without regard to the Calendar.

Stations equipped for making magnetic observations, but which cannot carry out such observations and reductions on a continuous schedule are encouraged to carry out such work at least on RWD (and during times of MAGSTORM Alert).

The International Ursigram and World Days Service (IUWDS) is a permanent scientific service of the International Union of Radio Science (URSI), with the participation of the International Astronomical Union and the International Union of Geodesy and Geophysics. IUWDS adheres to the Federation of Astronomical and Geophysical Services (FAGS) of the International Council of Scientific Unions (ICSU). The IUWDS coordinates the international aspects of the world days program and rapid data interchange.

This Calendar for 1983 has been drawn up by H.E. Coffey, of the IUWDS Steering Committee, in close association with A.H. Shapley, Chairman of MONSEE of SCOSTEP, and spokesmen for the various scientific disciplines in SCOSTEP, IAGA and URSI. Similar Calendars have been issued annually beginning with the IGY, 1957-58, and have been published in various widely available scientific publications.

Published for the International Council of Scientific Unions and with financial assistance of UNESCO.

Additional copies are available upon request to IUWDS Chairman, Dr. P. Simon, Ursigrammes Observatoire, 92190 Meudon, France, or IUWDS Secretary for World Days, Miss H.E. Coffey, WDC-A for Solar-Terrestrial Physics, NOAA, D63, 325 Broadway, Boulder, Colorado 80303, USA.

**Ionospheric Phenomena.** Special attention is continuing on particular events which cannot be forecast in advance with reasonable certainty. These will be identified by Retrospective World Intervals. The importance of obtaining full observational coverage is therefore stressed even if it is possible to analyze the detailed data only for the chosen events. In the case of vertical incidence sounding, the need to obtain quarterly-hourly ionograms at as many stations as possible is particularly stressed and takes priority over recommendation (a) below when both are not practical.

For the vertical incidence (VI) sounding program, the summary recommendations are: (a) all stations should make soundings at least every quarter hour. Stations which normally record at every quarter should, if possible, record more frequently on RWDs; (b) all stations are encouraged to make I-plots on RWDs. I-plots should be made for high latitude stations, and for so-called "representative" stations at lower latitudes for all days (i.e., including RWDs and WGIs). Continuous records of ionospheric parameters are acceptable in place of I-plots at temperate and low latitude stations; (c) copies of hourly ionograms with appropriate scales for QWDs are to be sent to WDCs; (d) stations in the eclipse zone and its conjugate area should take continuous observations on solar eclipse days and special observations on adjacent days. See also recommendations under Airglow and Aurora Phenomena.

For incoherent scatter observation programs, every effort should be made to obtain measurements at least on the Incoherent Scatter Coordinated Observation Days, and intensive series should be attempted whenever possible in WGIs or the Airglow and Aurora Periods. The need for collateral VI observations with not more than quarter-hourly spacing at least during all observation periods is stressed. Dr. M.J. Baron (USA), URSI Working Group G.5, is coordinating special programs.

For the ionospheric drift or wind measurement by the various radio techniques, observations are recommended to be concentrated on the weeks including RWDs.

For traveling ionosphere disturbances propose special periods for coordinated measurements of gravity waves induced by magnetospheric activity, probably on selected PRWD and RWD.

For the ionospheric absorption program half-hourly observations are made at least on all RWDs and half-hourly tabulations sent to WDCs. Observations should be continuous on solar eclipse days for stations in eclipse zone and in its conjugate area. Special efforts should be made to obtain daily absorption measurements at temperate latitude stations during the period of Absorption Winter Anomaly, particularly on days of abnormally high or abnormally low absorption (approximately October-March, Northern Hemisphere; April-September, Southern Hemisphere).

For back-scatter and forward scatter programs, observations should be made and analyzed on all RWDs at least.

For synoptic observations of mesospheric (D region) electron densities, several groups have agreed on using the RGD for the hours around noon.

For ELF noise measurements involving the earth-ionosphere cavity resonances any special effort should be concentrated during the WGIs.

It is recommended that more intensive observations in all programs be considered on days of unusual meteor activity.

**Meteorology.** Particular efforts should be made to carry out an intensified program on the RGD—each Wednesday, UT. A desirable goal would be the scheduling of meteorological rockets, ozone sondes and radiometer sondes on these days, together with maximum-altitude rawinsonde ascents at both 0000 and 1200 UT.

During WGI and STRATWARM Alert Intervals, intensified programs are also desirable, preferably by the implementation of RGD-type programs (see above) on Mondays and Fridays, as well as on Wednesdays.

**Middle Atmosphere Program (MAP).** MAP runs from 1 January 1982 through 1985. Techniques for observing the middle atmosphere should concentrate or center their observations on the RGDs, PRWDs, and QWDs. It is recommended that observing runs for studies of planetary waves and tides be at least 10 days centered on the PRWDs and QWDs. Non-continuous studies of stratospheric warmings and the effects of geomagnetic activity on the middle atmosphere must be initiated by STRATWARM and MAGSTORM alerts, respectively. For more details see the "Recommended Scientific Programs" on the reverse of the Middle Atmosphere Dynamics Calendar for 1983, which will be published as a special edition of the IGC for 1983.

**Solar Phenomena.** Observatories making specialized studies of solar phenomena, particularly using new or complex techniques, such that continuous observation or reporting is impractical, are requested to make special efforts to provide the WDCs data for solar eclipse days, RWDs and during PROTON/FLARE ALERTS. The attention of those recording solar noise spectra, solar magnetic fields and doing specialized optical studies is particularly drawn to this recommendation.

**Space Research, Interplanetary Phenomena, Cosmic Rays, Aeronomy.** Experimenters should take into account that observational effort in other disciplines tends to be intensified on the days marked on the Calendar, and schedule balloon and rocket experiments accordingly if there are no other geophysical reasons for choice. In particular it is desirable to make rocket measurements of ionospheric characteristics on the same day at as many locations as possible; where feasible, experimenters should endeavor to launch rockets to monitor at least normal conditions on the Quarterly World Days (QWD) or on RWDs, since these are also days when there will be maximum support from ground observations. Also, special efforts should be made to assure recording of telemetry on QWD and Airglow and Aurora Periods of experiments on satellites and of experiments on spacecraft in orbit around the Sun.

For URSI/IAGA Coordinated Tidal Observations Program (CTOP) contact Dr. R.G. Roper (USA) for the 1983 calendar.